

The PC-12 NG Revolution



YOUR PARTNER in the sky

POWERED BY

AIR-DYNAMIC
ANYWHERE. ANYTIME.

Club
St.X





The smartest Swiss way to travel in Europe

From Lugano and Locarno easily connected to all the main European destinations, in a simple, fast and innovative way.

This is what the **St.X Club** offers you today: a smart formula to reach your destinations stress free, starting from **Lugano** or **Locarno**, without wasting time and optimizing travel time. **St.X operates the Pilatus PC-12 NG**, an aircraft that is comfortable using international airports as well as small airfields. Due to the unique Pilatus PC-12 NG performances and features, **you can access 3 times more airfields than a traditional business jet. With St.X save time by landing closer to your final destination.** We guarantee maximum comfort, global management of your transfer, logistical support, 24h assistance 7 days a week. Everything is much simpler and more immediate.

PC-12

No





Crafted in Switzerland

The world's greatest single engine

To offer maximum performance and flexibility, we offer the innovative **Pilatus PC-12 NG private jet, designed, developed and produced in Switzerland.** A single engine with very high performance and with the exclusive ability to use short tracks (half of a similar aircraft of the same size). Able to operate from runways made of dirt, gravel, and grass, the PC-12 NG can take you to places you've never been in a business aircraft before. The **PC-12 NG** can use **+84%** of tertiary airports compared to similar aircrafts which means **unbeatable proximity to your final destination.** The **PC-12 NG** has a high load capacity and offers a very high standard in terms of safety. Suitable for business or pleasure trips it is configured to carry **up to 8 passengers plus 2 crew members.**



Swiss
Quality



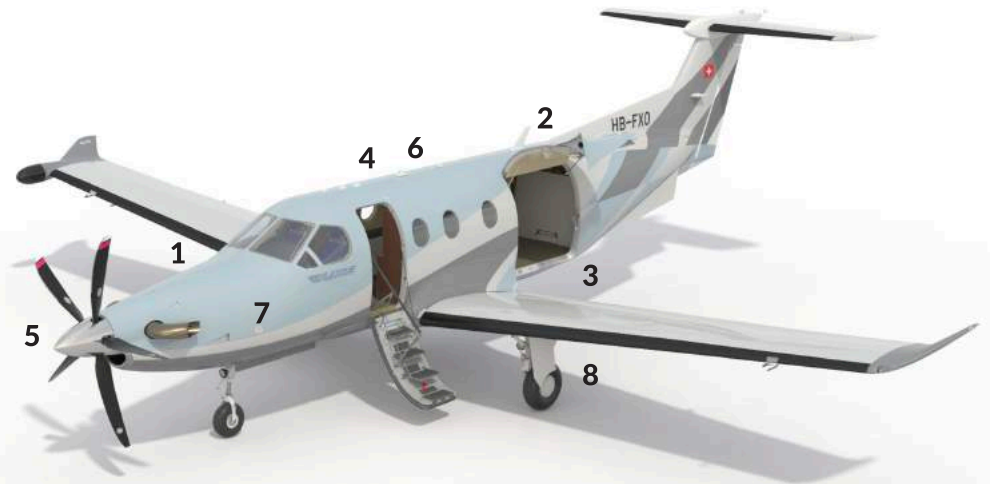

1. Honeywell Primus Apex Integrated Avionics System for easy single-pilot operation
2. Large cargo door (4 ft. 5 in × 4 ft. 4 in / 1.35 m x 1.32 m) on left-hand side of fuselage
3. Flat floor cabin which can easily be adapted for various uses
4. Spacious and pressurized cabin with 330 ft³ (9.34 m³) cabin volume and space for up to 9 passengers
5. Hartzell five-blade composite propeller
6. Interior design by BMW Design works USA
7. 81,200 shp Pratt & Whitney Canada PT6A-67P turboprop engine (1,845 shp thermodynamic power)
8. Landing gear designed for unimproved field operations

High Level
Performances





The Pilatus PC-12 NG has gained a reputation for outstanding versatility, performance, reliability and operational flexibility. As such, it is one of the most popular turbine-powered business aircraft on the market today. Whether it is the large cabin, single pilot operations, long range, high speed, short-field capability, or precision Swiss engineering and construction, **customers find the perfect balance of features to serve their needs in the PC-12 NG.**

Take-off distance

Over 50 ft. Obstacle (MTOW) 2.600 ft. 792 m

Rate of climb

Sea Level (MTOW) 1.920 fpm 585 m/min

Time To Climb Sea Level To FL 250 20 min (MTOW)

Cruise

Maximum Cruise Speed (FL 220) 285 KTAS 528 km/h

Payload / range

Max Payload (2.257 lb.) 651 nm 1.206 km

6 passengers (1.200 lb. payload) 1.460 nm 2.704 km

4 passengers (800 lb. payload) 1.617 nm 2.995 km

Altitude

Max Certified Altitude 30.000 ft. 9.144 m

Landing distance

Over 50 ft. Obstacle 2.170 ft. 661 m (MLW, no reverse)

Stall speed

(MTOW) 67 KIAS 124 km/h



Interior Configurations

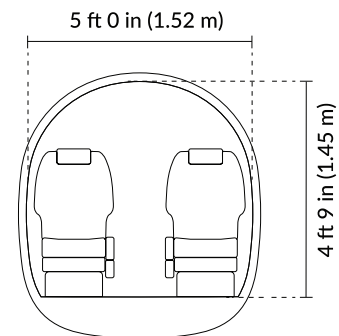

Go Ahead and Stretch Your Legs

Welcome to the “Pilatus Class”. The PC-12 NG’s cabin volume is greater than most turboprops and medium sized business jets costing often twice as much. Executive seats engineered for comfort and in-flight access to the baggage compartment set the stage for any trip – quick hop or long haul. A spacious, discrete lavatory is integrated into the forward portion of the cabin offering complete privacy without infringing on baggage space

Cabin Space



Max Passengers
6/8 + 2 PILOTS

With 330 cubic feet (9.34 cubic meters) of cabin volume, you will enjoy more space than business jets costing twice as much. A flat floor gives your passengers more comfort and gives you the ability to easily load just about any cargo you can fit.

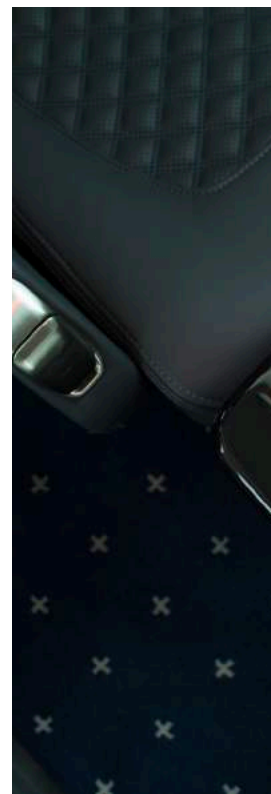
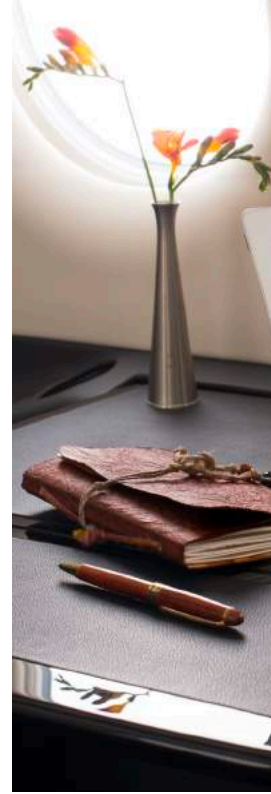



Welcome on board for
those who don't travel light



Big things can be expected from such a big door. The PC-12 NG is the only business aircraft to feature a pallet-sized cargo door as standard. But without practical cabin volume, the door is simply a grand opening. The PC-12 NG features an impressive cargo space that takes advantage of the flat floor architecture within, providing a multitude of uses.

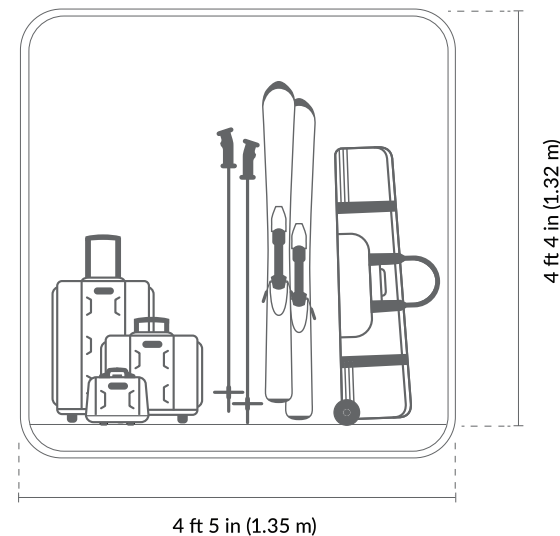



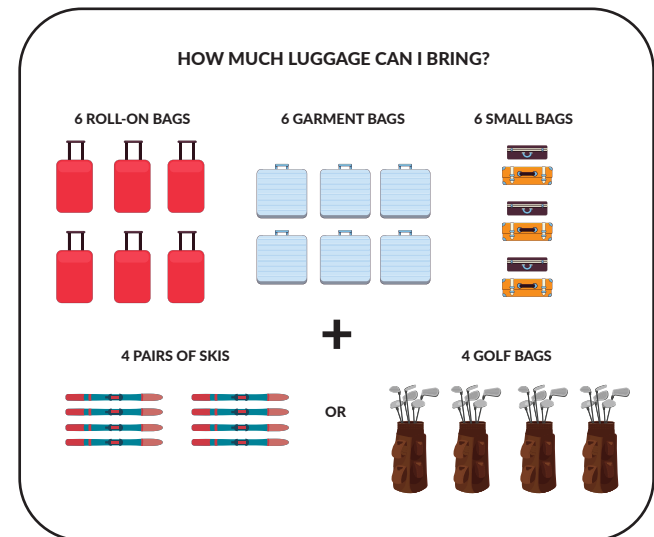

In addition, **your baggage is easily accessible during flight in the heated and pressurized cabin section.** The generous center of gravity (CG) range of the PC-12 NG coupled with the quick-change interior contributes to its legendary versatility. So, on your next trip, you may not have to choose what you bring - just take it all.



YOUR NEXT
Destination

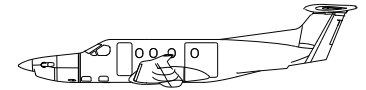



Pilatus PC-12 NG 

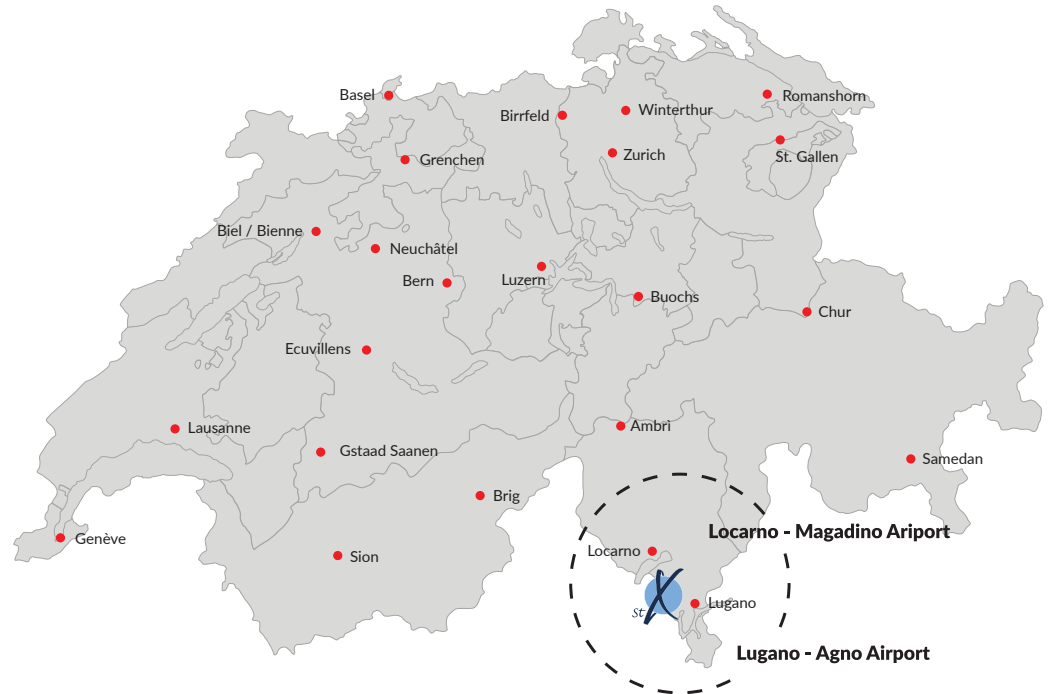

Departure from Home

Choosing **St.X** as your partner will allow you to **reach your main destinations in Switzerland from Lugano or Locarno**, in the maximum comfort and in the shortest time possible.





LUGANO - GENEVE

By commercial airline via Zürich: 3h15

By train: 6h

PC-12 NG: 45 minutes

LUGANO - BERN

By car: 3h15

By train: 3h40

PC-12 NG: 45 minutes

LUGANO - ST. MORITZ

By car: 2h40

PC-12 NG: 25 minutes

LUGANO - ST. GALLEN

By car: 2h50

By train: 3h15

PC-12 NG: 45 minutes

LUGANO - GSTAAD

By car: 3h50

By train: 6h

PC-12 NG: 40 minutes

LUGANO - LAUSANNE

By car: 4h15

By train: 4h45

PC-12 NG: 50 minutes

LUGANO - BASEL

By car: 3h

By train: 3h15

PC-12 NG: 45 minutes

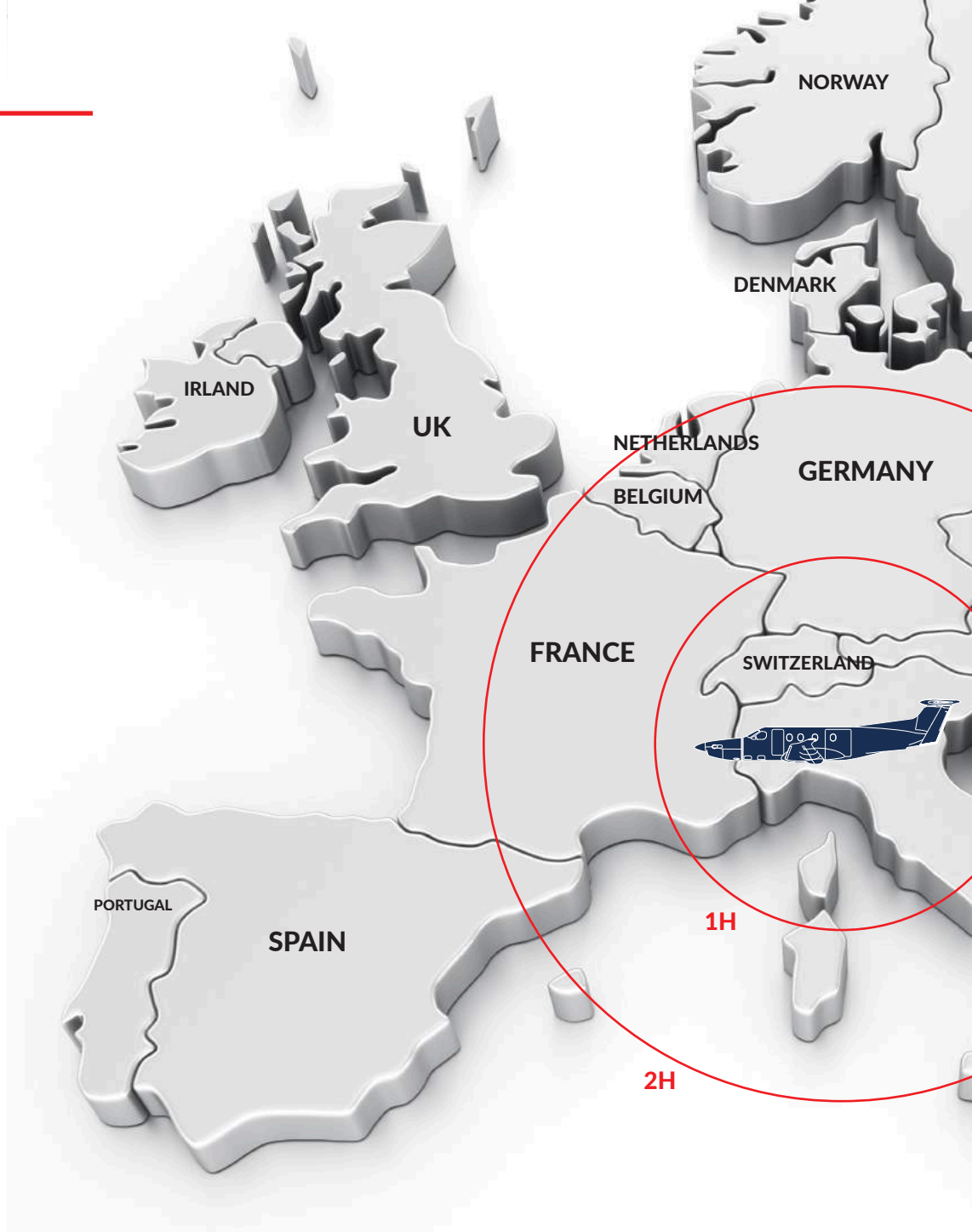

Switzerland *Closer to you*

Travel in *Europe*



Departure from Lugano

LONDON: 2h 15 minutes

FRANKFURT: 1h 15 minutes

PARIS: 1h 15 minutes - ST. TROPEZ: 50 minutes

NICE: 45 minutes - CANNES: 50 minutes

BARCELONA: 1h 50 minutes - IBIZA: 1h 50 minutes

PALMA DE MALLORCA: 1h 50 minutes - MALAGA: 2h 30 minutes

ROME: 1h 15 minutes - VENICE LIDO: 50 minutes

ELBA ISLAND: 60 minutes - SARDINIA: 1h 15 minutes

MIKONOS: 2h 50 minutes - ATHENS: 2h 50 minutes

MONTENEGRO: 1h 35 minutes

Any Other
**DESTINATION
ON REQUEST**





Excellence and Professionalism

Air-Dynamic SA, specialized in providing services by private jets and helicopters with its long-time experience is based in Lugano-Agno airport and is **the official and exclusive Partner of St.X**. In Air-Dynamic we work to understand your requirements and preferences and within short time offer you quality and best price solutions

on single and multiple stage transfers that will get you from door to door safely & efficiently, relaxed and in style. Professionalism and a solid international network are just a few of the factors that distinguish us and which allow you to plan your travels in comfort, if it's for business or for pleasure.



Leisure and Business travel

- Fast and smooth organization of transfers from any locations to your holiday or business destination
- Pick up and drop off directly to your hotel room or your private home
- Coordination at 360° of your entire logistic
- Minimum of **3 hours** notice required

VIP SERVICE

- Hotel booking
- Transfer of minors and pets
- Personalized Catering
- Total privacy, comfort and reliability



How to become a member:

Email: info@st-x.ch | Office: +41 916053306 / Mobile: +41 789725494

Via Aeroporto 15, 6982 Agno - Lugano Airport (Switzerland)



www.st-x.ch